

SECTION A-A

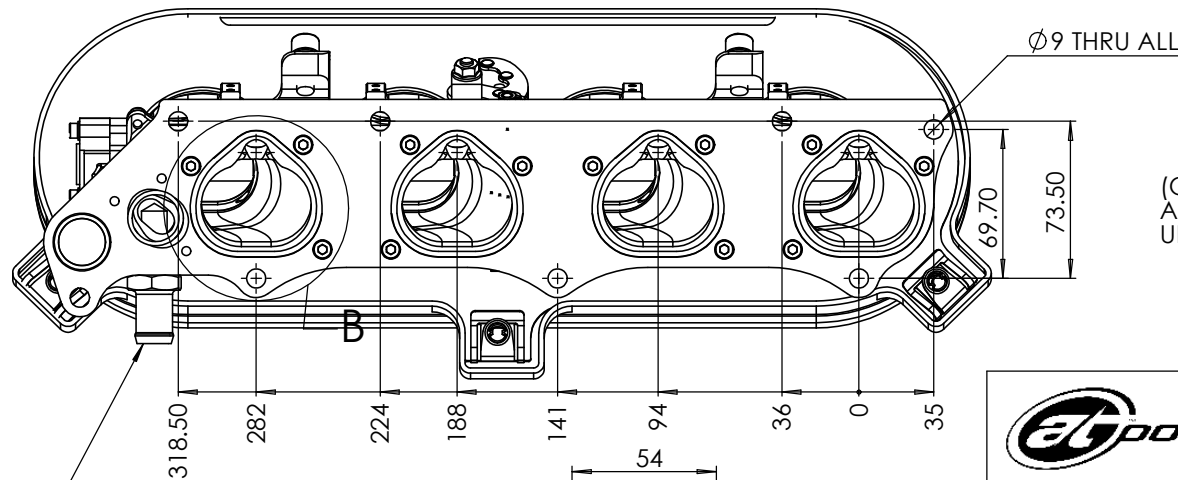

(OPTIONAL) AIR FILTER AND UNDRILLED BACK PLATE

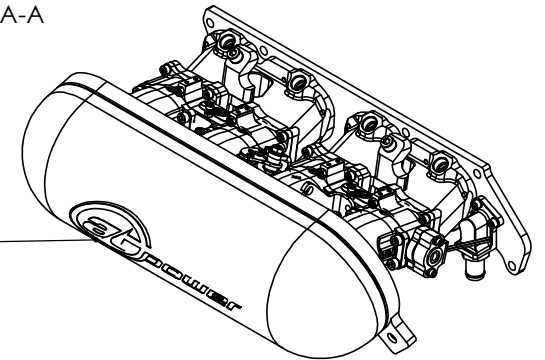

WATER OUTLET  
17mm O/D  
HOSE FITTING

NOTE:  
THIS PRODUCT REQUIRES AN  
AFTERMARKET ENGINE MANAGEMENT  
SYSTEM (ECU) FOR CORRECT ENGINE  
FUELING OPERATION

TRUE R18.75

14.8

DETAIL B  
SCALE 1:2



COPYRIGHT (c) 2013  
AT POWER LTD  
UNIT 9, CHESTNUT DRIVE, WYMONDHAM,  
NORFOLK, UK, NR18 9SB

UNLESS OTHERWISE STATED:  
DIMENSIONS IN MILLIMETRES  
TOLERANCES: LINEAR ± 0.1 ANGULAR ± 0.5°  
SURFACE FINISH - √ = √  
DRAWING STANDARDS TO ATQS 6003  
DATE FORMAT: DD/MM/YY

THIS DESIGN IS THE PROPERTY OF  
AT POWER THROTTLES LTD AND  
MUST NOT BE REPRODUCED OR  
COMMUNICATED WITHOUT  
AUTHORITY

CAD PLOT  
DO NOT  
SCALE

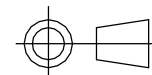

THIRD ANGLE PROJECTION

SCALE 1:2.5 WEIGHT 5871.744 kg

DRAWN - S.HOW

DATE - 03/05/22

CHECKED - S.HOW

APPROVED - A.CLIFTON

MATERIAL

SEE COMPONENT PARTS

FINISH

SEE COMPONENT PARTS

DRAWING TITLE

ASSY-TWIN-HONDA-K20-FD2-  
STAGGERED-STANDARD  
INSTALLATION KIT-OPEN INTAKE

DRAWING NUMBER

102-102-00368