

NOTE:
THIS PRODUCT REQUIRES AN AFTERMARKET ENGINE MANAGEMENT
SYSTEM (ECU) FOR CORRECT ENGINE FUELLING OPERATION

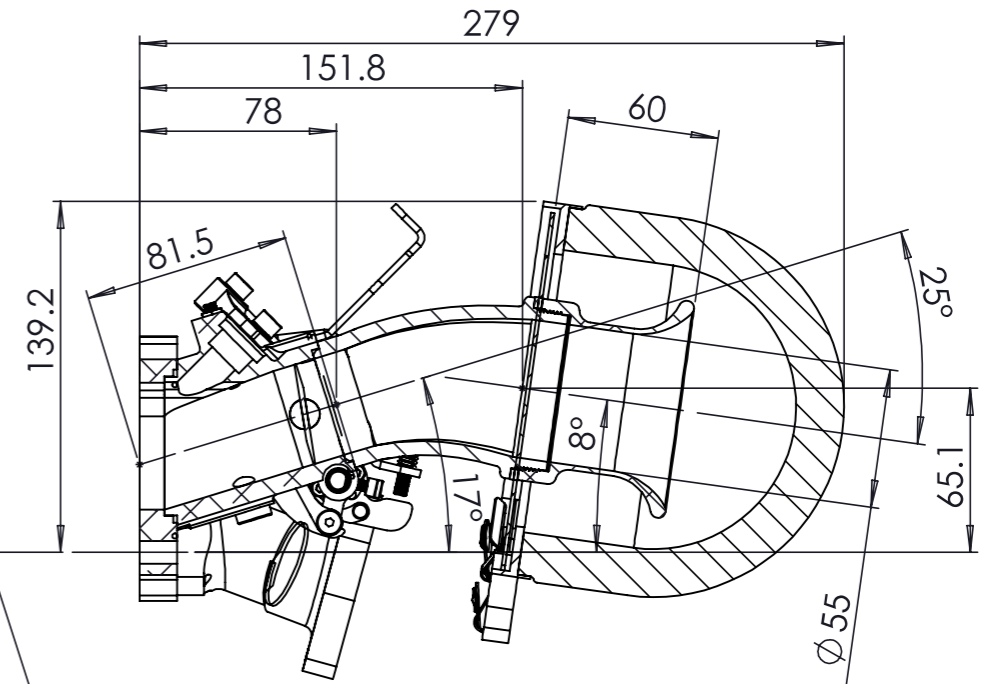

SECTION A-A

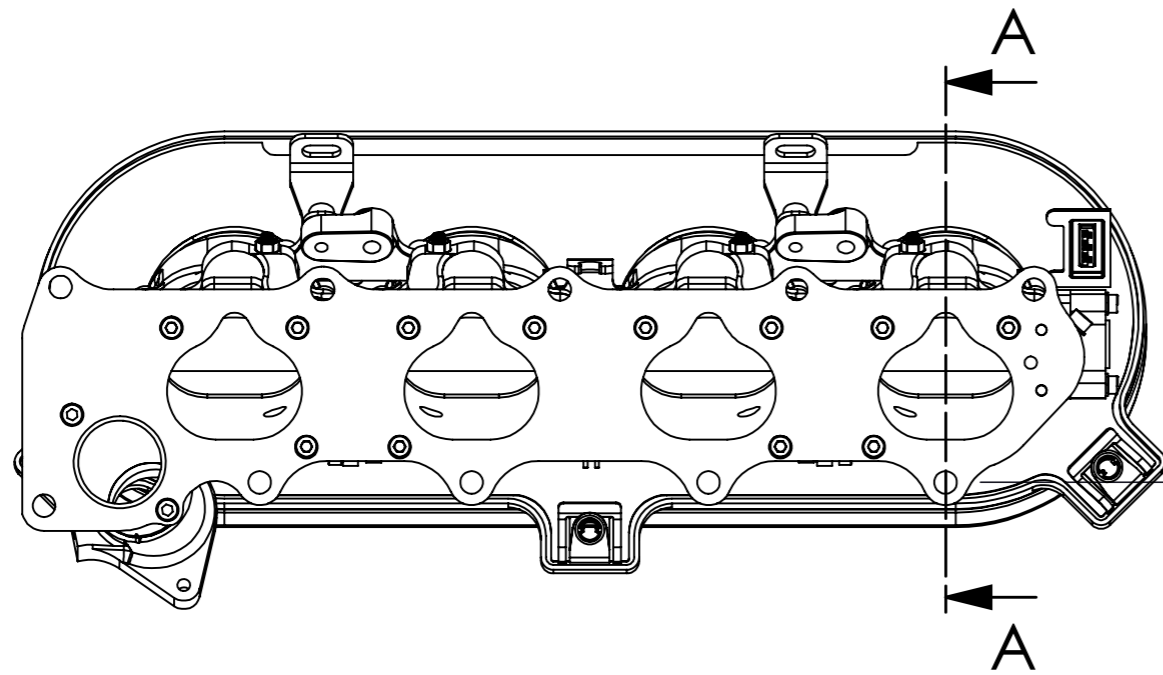
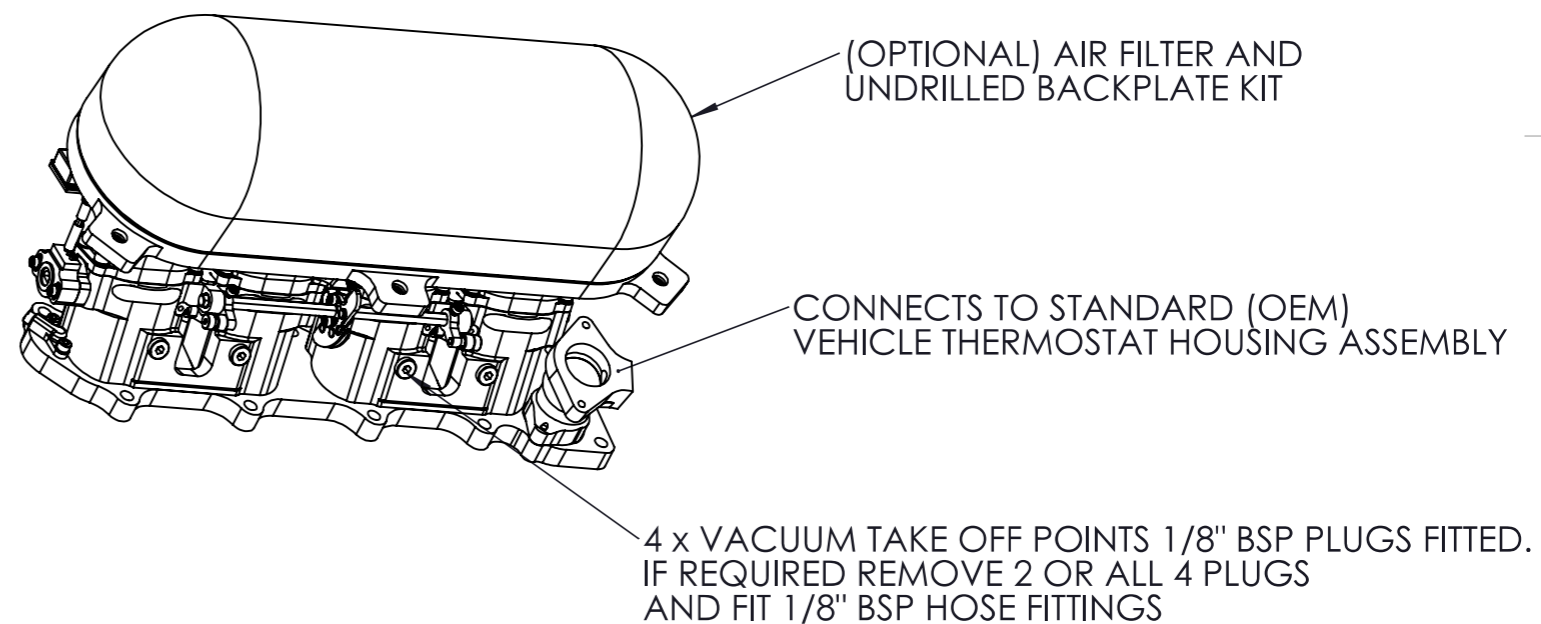

CONNECTS TO STANDARD (OEM) VEHICLE
THROTTLE CABLE PICK-UPS

USE STANDARD (OEM) FUEL
INJECTORS & FUEL RAIL ASSEMBLY

USE STANDARD (OEM)
INTAKE GASKET

ROTARY POSITION SENSOR
SUPPLIED WITH KIT



COPYRIGHT (c) 2013
AT POWER LTD
UNIT 9, CHESTNUT DRIVE, WYMONDHAM,
NORFOLK, UK, NR18 9SB

UNLESS OTHERWISE STATED:
DIMENSIONS IN MILLIMETRES
TOLERANCES: LINEAR ± 0.1 ANGULAR $\pm 0.5^\circ$
SURFACE FINISH $\nabla = \nabla$
DRAWING STANDARDS TO ATQS 6003
DATE FORMAT: DD/MM/YY

THIS DESIGN IS THE PROPERTY OF
AT POWER THROTTLES LTD AND
MUST NOT BE REPRODUCED OR
COMMUNICATED WITHOUT
AUTHORITY

CAD PLOT
DO NOT
SCALE

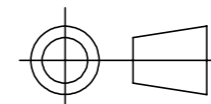

THIRD ANGLE PROJECTION

SCALE 1:3 WEIGHT 7.4 kg

DRAWN- S.HOW

DATE- 20/01/22

CHECKED - S.HOW

APPROVED - A.CLIFTON

MATERIAL

SEE COMPONENT PARTS

FINISH

SEE COMPONENT PARTS

DRAWING TITLE

ASSY - HONDA F20/S2000 -
52MM - STANDARD
INSTALLATION KIT

DRAWING NUMBER

102-102-00346