

SECTION A-A

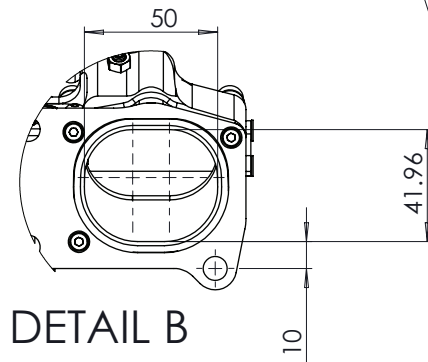

DETAIL B



COPYRIGHT (c) 2013  
AT POWER LTD  
UNIT 9, CHESTNUT DRIVE, WYMONDHAM,  
NORFOLK, UK, NR18 9SB

UNLESS OTHERWISE STATED:  
DIMENSIONS IN MILLIMETRES  
TOLERANCES: LINEAR  $\pm 0.1$  ANGULAR  $\pm 0.5^\circ$   
SURFACE FINISH  $\sqrt{\quad} = \sqrt{\quad}$   
DRAWING STANDARDS TO ATQS 6003  
DATE FORMAT: DD/MM/YY

THIS DESIGN IS THE PROPERTY OF  
AT POWER THROTTLES LTD AND  
MUST NOT BE REPRODUCED OR  
COMMUNICATED WITHOUT  
AUTHORITY

CAD PLOT  
DO NOT  
SCALE

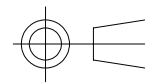

THIRD ANGLE PROJECTION

SCALE 1:2	WEIGHT 1.7 kg
--------------	------------------

DRAWN- S.HOW

DATE - 01/12/20

CHECKED - S.HOW

APPROVED - A.CLIFTON

MATERIAL

SEE COMPONENT PARTS

FINISH

SEE COMPONENT PARTS

DRAWING TITLE

ASSY-HOUSING-TWIN-FORD-  
DURATEC-45MM-2.5L WITH 2.5L  
PORT PROFILE

DRAWING NUMBER

102-104-00087

SHEET 2 OF 2 A3